



ExchangeRisk

EXperimental & **C**omputational **H**ybrid **A**ssessment of **N**atural
Gas Pipelines **E**xposed to Seismic **R**isk



UNIVERSITÀ DEGLI STUDI
DI NAPOLI FEDERICO II

WP2 - Hybrid experimentation on principle failure modes of the soil-pipeline system



Project Workshop 18/06/2018

Quick Update – UNAP secondment progress

ExchangeRisk



Total secondment man-months completed or planned: **11 MM**



Roberto Baraschino
(early stage researcher)



Pasquale Cito
(early stage researcher)

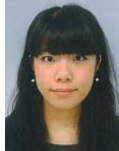

Akiko Suzuki
(early stage researcher)



Eugenio Chioccarelli, Ph.D
(experienced researcher)



Georgios Baltzopoulos, Ph.D. M.Sc.
(experienced researcher)

One month

One month (completed)

Two months (plan 2018)

One month

One month

One month

Two months (completed)

Two more months planned in 2018





Bull Earthquake Eng
https://doi.org/10.1007/s10518-017-0295-3



ORIGINAL RESEARCH PAPER

Seismic actions on structures in the near-source region of the 2016 central Italy sequence

Iunio Iervolino¹ · Georgios Baltzopoulos² · Eugenio Chioccarelli³ · Akiko Suzuki¹

Received: 25 July 2017 / Accepted: 4 December 2017
© Springer Science+Business Media B.V., part of Springer Nature 2017

Abstract The central Italy seismic sequence began in the latter half of 2016 and continued well into 2017, causing severe damage in the villages close to the source and causing hundreds of casualties. It is a sequence especially interesting to study, from the perspective of seismic actions experienced by structures, because it saw nine $M \geq 5.0$ earthquakes within a period of 5 months, rupturing parts of the complex central Apennine mountain range fault system. Consequently, some of the main earthquake engineering issues that arose are the multiple locations where the code-mandated seismic actions were exceeded in more than one of the main events of the sequence and the number of pre- and low-code existing buildings that suffered heavy damage or collapse due to the intensity of individual earthquakes and the cumulative effect of repeated damaging shocks. The present article picks up on these topics and uses probabilistic seismic hazard, as well as the multitude of strong ground motion recordings available from the sequence, to provide a discussion on certain issues, that are all related to the topical subject of seismic actions. These issues are: (1) the unsurprising exceedance of code spectra in the epicentral areas of strong earthquakes; (2) the particular spectral shape and damaging potential of near-source, pulse-like, ground motions, possibly related to rupture directivity; and (3) structural non-linear behaviour in the wake of a sequence that produces repeated strong shaking without the necessary respite for repair and retrofit operations.

Keywords Seismic hazard · Pulse-like ground motion · Cumulative damage

✉ Iunio Iervolino
iunio.iervolino@unina.it

¹ Dipartimento di Strutture per l'Ingegneria e l'Architettura, Università degli Studi di Napoli Federico II, Naples, Italy

² Istituto per le Tecnologie della Costruzione, Consiglio Nazionale delle Ricerche (ITC-CNR), Naples, Italy

³ Università Telematica Pegaso, Naples, Italy

Published online: 09 December 2017

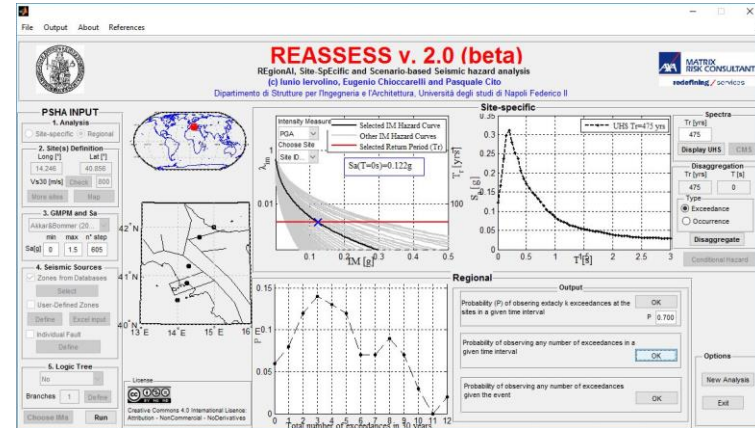

E. Chioccarelli, P. Cito, I. Iervolino, M. Giorgio. “REASSESS V2.0: software for single- and multi-site probabilistic seismic hazard analysis”, submitted to Bulletin of Earthquake Engineering



UNIVERSITÀ DEGLI STUDI
di NAPOLI FEDERICO II



University of
BRISTOL



ΠΑΝΕΠΙΣΤΗΜΙΟ
ΠΑΤΡΩΝ
UNIVERSITY OF PATRAS

OBJECTIVE

Develop a demonstration-size low-power actuator and write the necessary software for the controller.

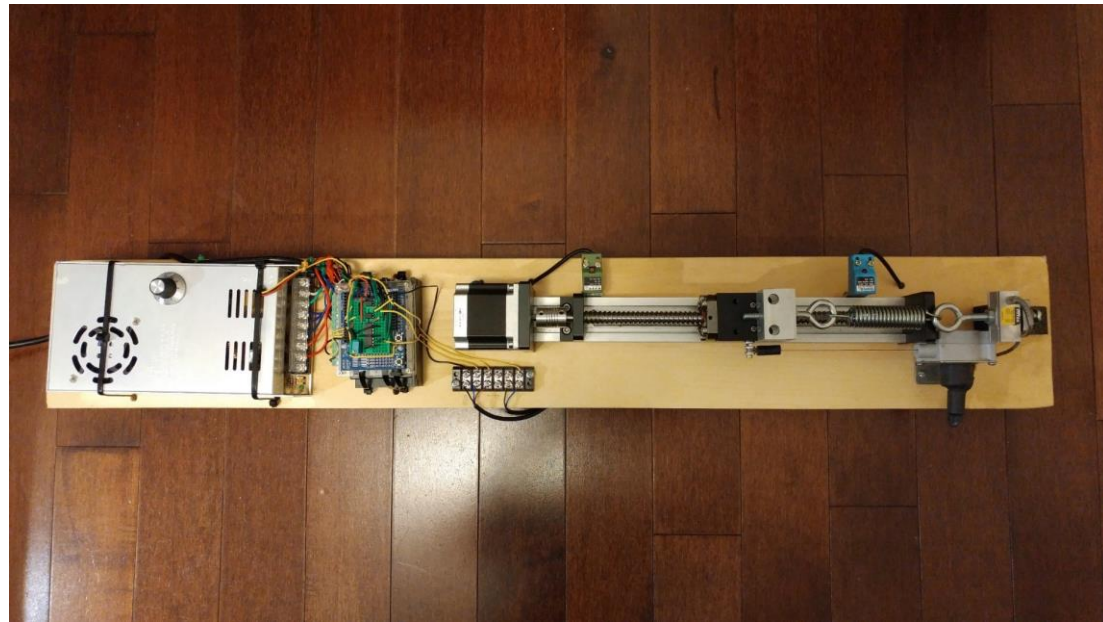

WP2 - Mini Hybrid Setup

Universities of Toronto, Naples, Bristol and Patras



UNIVERSITÀ DEGLI STUDI
di NAPOLI FEDERICO II

CONCEPT

Enable the testing and calibration of hybrid simulation protocol prior to going lab-scale, in support of EXCHANGE-RISK Hybrid experimentation.



Photo from UoT lab, taken during the April 2017 UT-SIM workshop

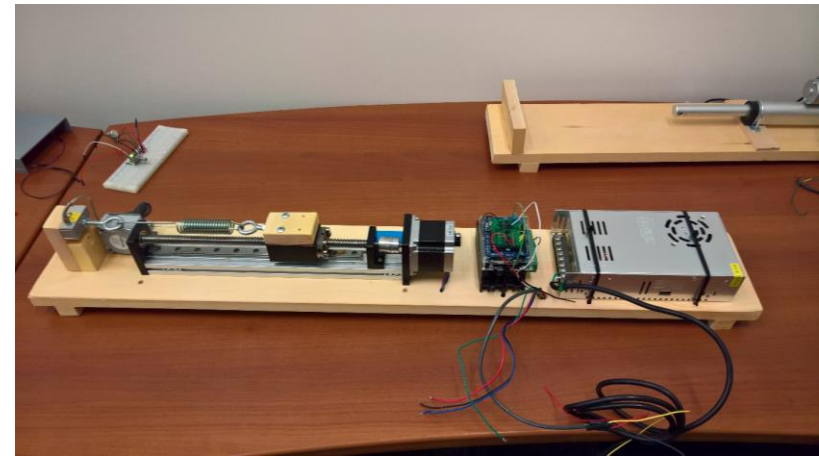

Mini hybrid setup prototype under development at UoT during EXCHANGE-RISK secondment

WP2 - Mini Hybrid Setup

Universities of Toronto, Naples, Bristol and Patras



UNIVERSITÀ DEGLI STUDI
DI NAPOLI FEDERICO II

IMPLEMENTATION

Cost-effectiveness: relatively low-cost components, maintaining accuracy requirements within the scope of the device (total cost in the 1000-1500 euro range).

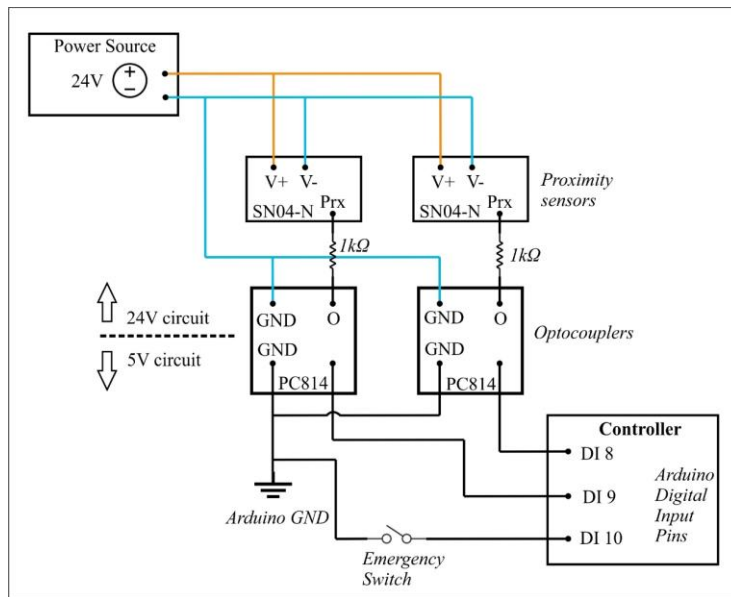

Separation of medium- and low-voltage circuits

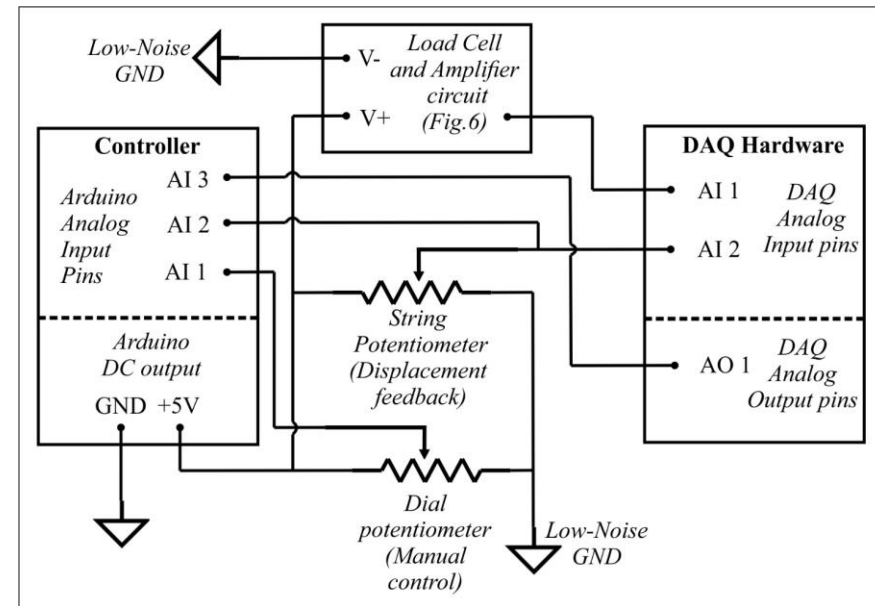

Communication with DAQ, overrides and NICON hybrid simulation protocol.

WP2 - Mini Hybrid Setup

Universities of Toronto, Naples, Bristol and Patras



UNIVERSITÀ DEGLI STUDI
DI NAPOLI FEDERICO II

IMPLEMENTATION

Electric actuator driven by stepper motor and controlled by an Arduino board.

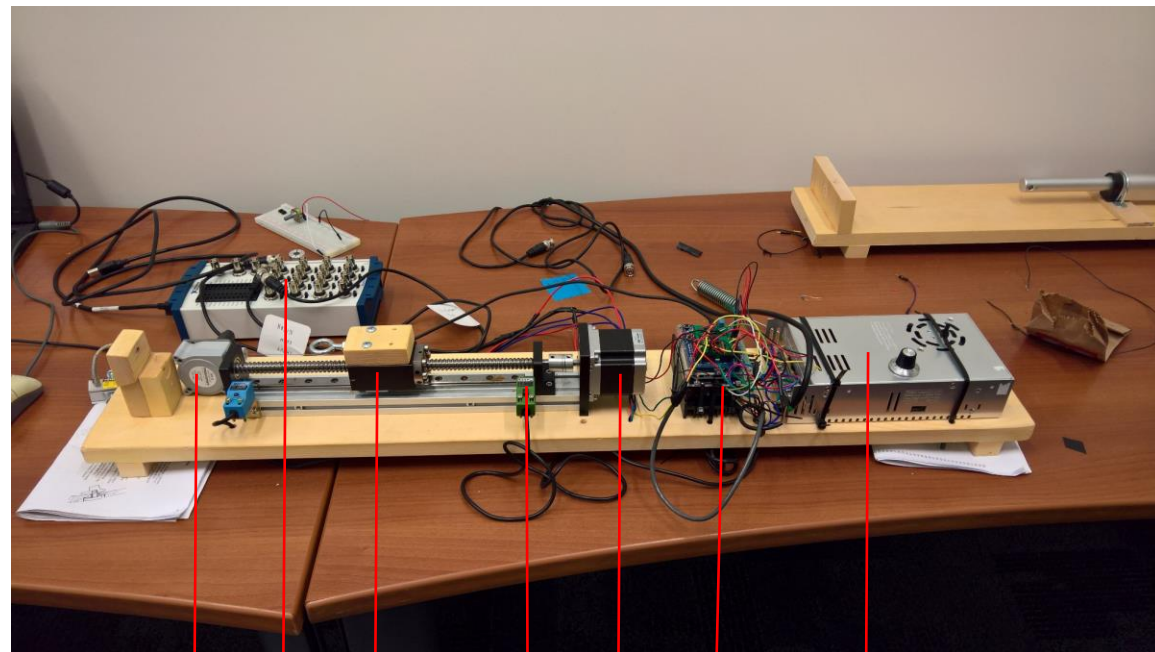
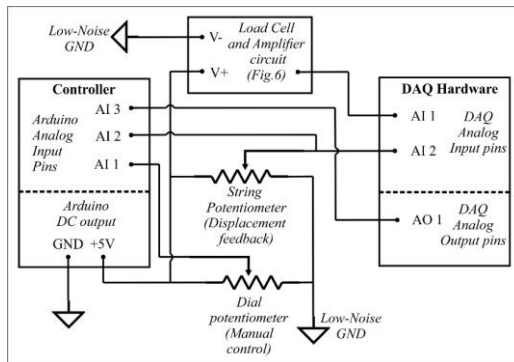
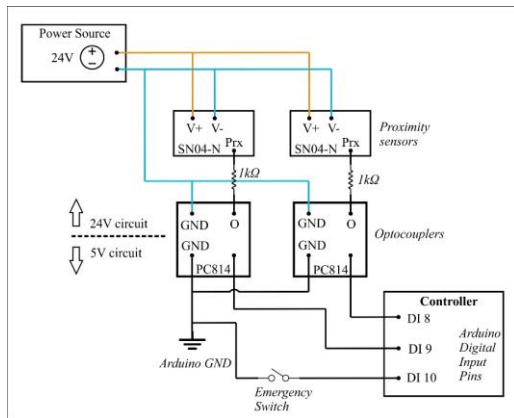

String pot

traveller

Step motor

Power supply

DAQ

sensor

Controller & step driver

WP2 - Mini Hybrid Setup

Universities of Toronto, Naples, Bristol and Patras



UNIVERSITÀ DEGLI STUDI
DI NAPOLI FEDERICO II

REPRODUCIBILITY

Secondment deliverable: detailed report permitting replicate mini hybrid setups to be assembled at partner institutions.

Exchange Risk

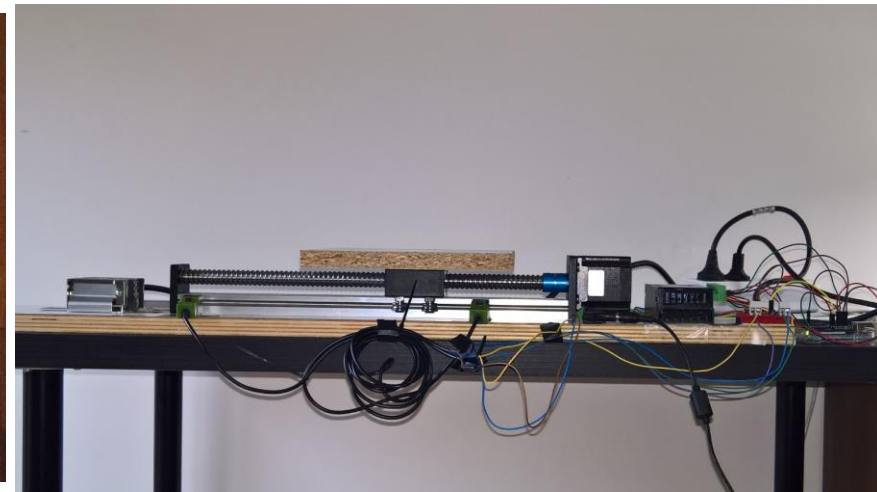
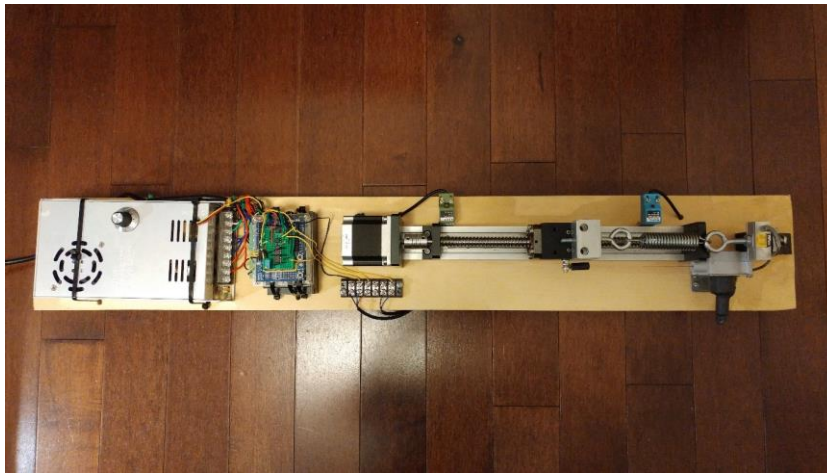
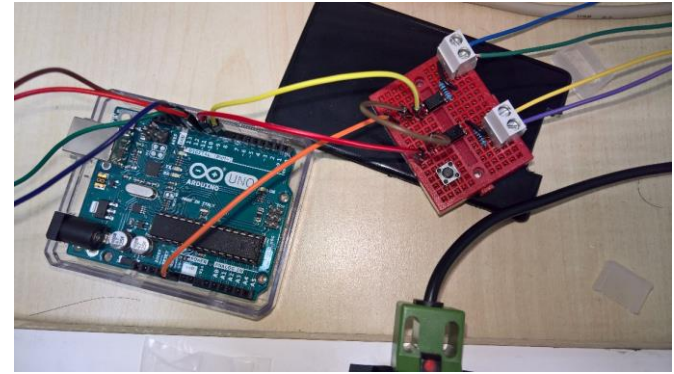
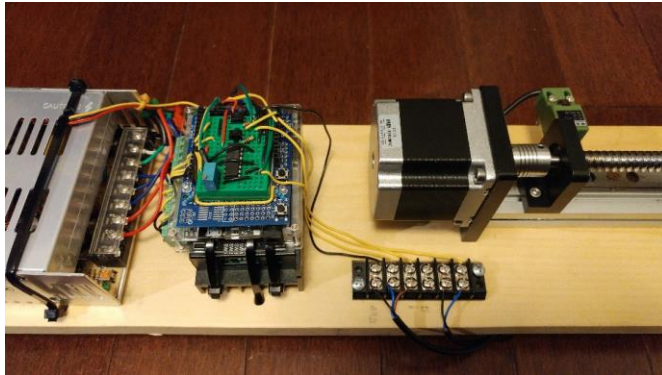

Prototype at University of Toronto

Duplicate of the prototype set-up at the university of Naples

WP2 - Mini Hybrid Setup

Universities of Toronto, Naples, Bristol and Patras



UNIVERSITÀ DEGLI STUDI
di NAPOLI FEDERICO II

DEMONSTRATION

Toronto, October 2017: Demo run of small scale hybrid simulation using NICON and OPENSEES

Video. Demonstration of small-scale hybrid simulation underway. The computer is solving a two-degree-of-freedom system under seismic excitation, using the OPENSEES open finite element analysis platform and communicating with the demo-actuator via NICON labview-based platform developed at UoT. During this demo, there is no physical specimen attached to the actuator; instead the displacement feed is wired into the load-cell feed and converted into force readout via NICON (user-defined nonlinear force-displacement rule).

Outline of research activities during secondment

Pseudo-dynamic testing, due to its various perceived advantages in the context of experimental earthquake engineering, has given rise to another variant that introduces sub-structuring, termed hybrid simulation. Within the framework of the EXCHANGE-RISK project, it is envisaged to implement this method for the experimental identification of the principal failure modes of soil-pipeline systems.

